

# TF840D - Forwarder

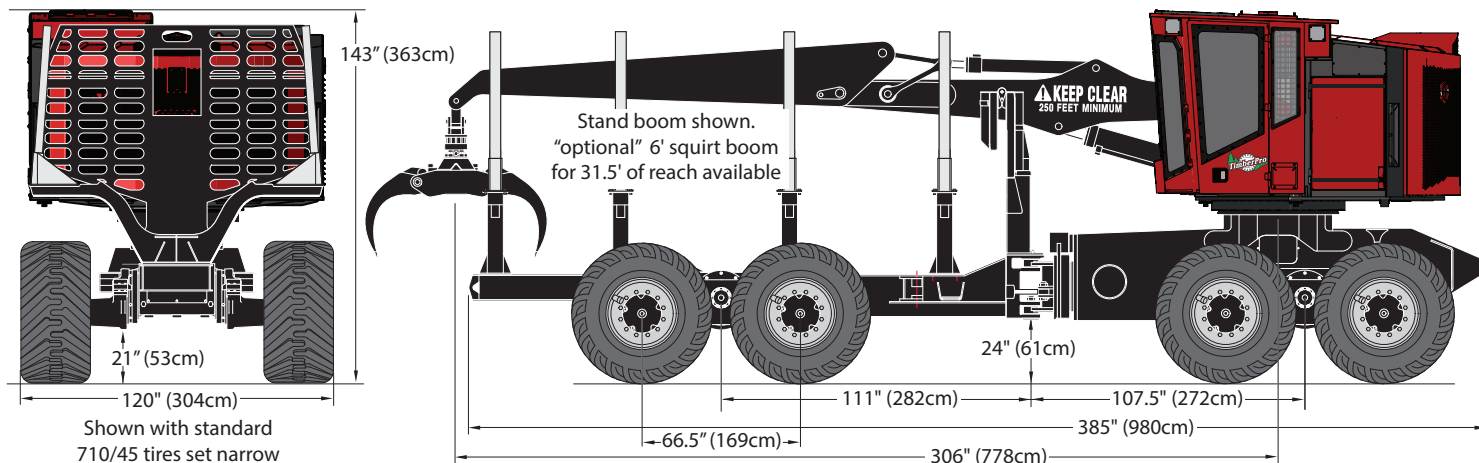

TimberPro Inc reserves the right to change specifications without notice or obligation. Product illustrations may be equipped with non-standard equipment.

## Engine:

Cummins L9 Series Engine  
Single Module DOC/DPF/SCR  
Max HP - 338 hp (252 kw)  
Fuel Tank - 100 gallons (378 Liters)

## Cooling:

Fan - 42" Hydraulic Driven,  
Variable Speed with Auto Reversing Feature

## Control System:

IQAN MD4 HD control system

- 10" touch screen
- Engine Management
- Troubleshooting Diagnostics
- Over and Under Temperature Protection

## Electrical System:

Alternator - 100 amp 24 Volt  
Batteries - 2 /12 Volt @ 1000 CCA  
Work Lights - LED High Intensity Lighting

## Serviceability:

Rear Gull Wing Canopy Opens to Access to  
Engine and Hydraulic Components  
Side Access Service Doors  
Retractable step for operators cabin  
Hydraulic Tank Vacuum System

## Hydraulic System:

Implement Pump - 145cc Variable Disp Piston  
Swing Pump - Dedicated 90cc Hydrostatic  
Drive Pump - Dedicated 120cc Dual Hydrostatic  
Charge Pump - Gear Pump 50cc  
Valve - Parker L90LS / K220  
Electric hyd oil fill pump

## Filtration System:

Charge Filter Non By-Pass 6 micron  
Return Filters w/By-Pass 10 micron  
Case Drain Filter w/By-Pass 10 micron

## Upper Turntable Swing:

Gearbox - Rexroth GFB17 (45.66:1)  
Swing Motor - Rexroth Bent Axis - 56cc  
Hydrostatic energy recovery system  
Continuous Rotation Swing

## Safety:

ANSUL LVS 15 Gallon Liquid Agent Fire  
Suppression System

## Optional Items:

6' Telescopic Squirt Boom  
Front Frame Power Step  
Hultdins 360s grapple  
Clam Bunk Attachment  
26" HD Frame Brake

## Machine Weight:

Base Machine: 60,100 (27,260 kg)

*(approximate "woods ready" operating weight without attachment)*

## Boom Performance:

Maximum Reach (Pin Point) - 31.5 ft (9.6 m)  
Lift Capacity @ Max Reach - 6,320 lbs (2,866 kg)  
Lift Capacity @ 15' (4.6 m) - 12,880 lbs (5,842 kg)

## Axles, Gearbox and Tires:

Axle Front - NAF Bogie 22 ton  
Axle Rear - NAF Bogie 22 ton  
Gearbox - NAF Dual Speed  
Tires - 710 / 45 (Standard)  
Tires - 750 / 55 (Optional)

## Operators Cabin:

ROPS/FOPS/OPS Certified cabin  
Digital Climate Control System  
Three Emergency Escape routes  
Fresh air filtered & Pressurized cabin  
AM/FM/WB - Bluetooth/Handsfree - USB  
Deluxe Seat - Air ride, Heat & Lumbar  
Rear View Camera System

[www.timberpro.com](http://www.timberpro.com)