

Section LV-2

Leveling Track Frame - Leveling Components

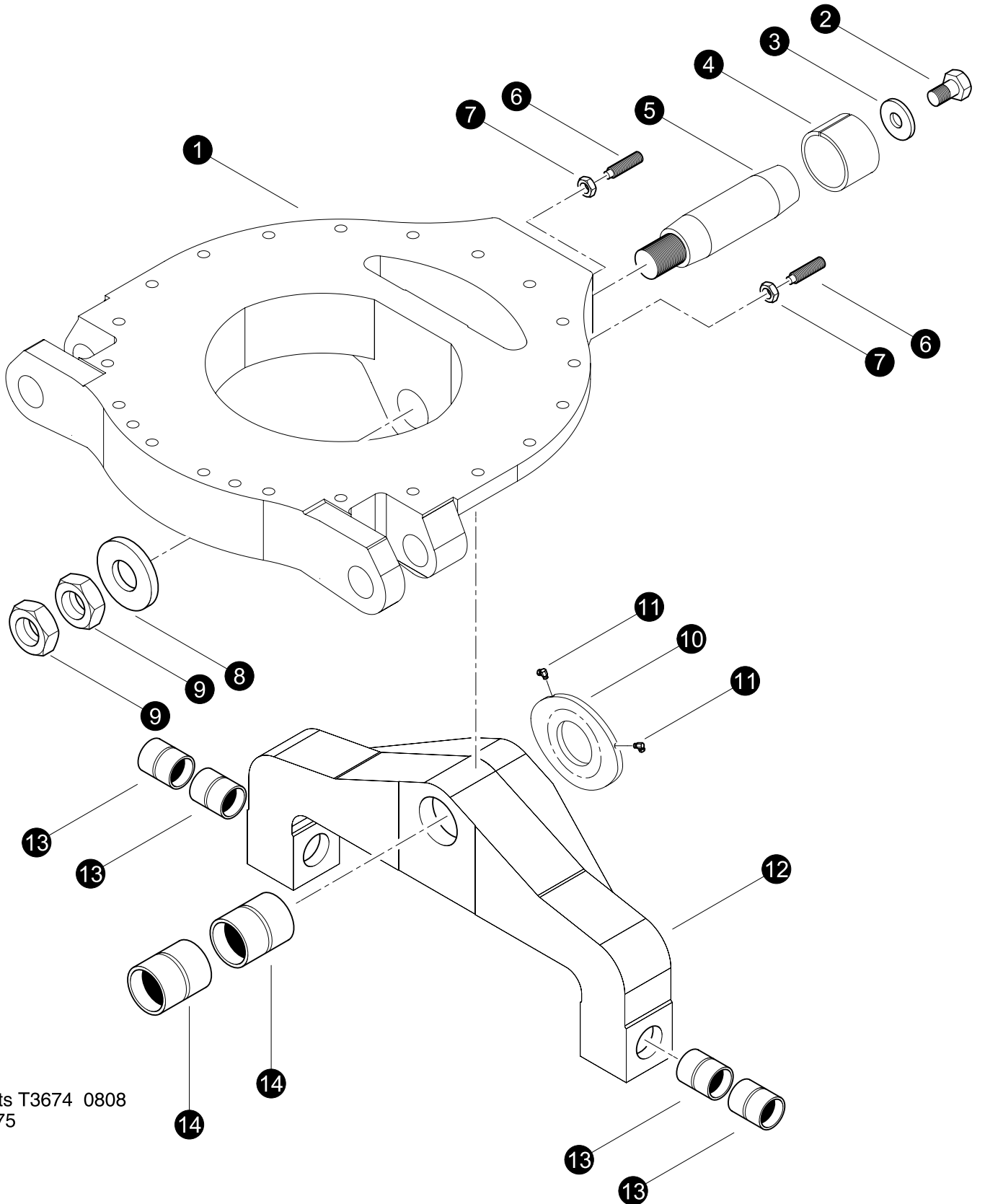

Parts T3674 0808
9.375

Leveling Components (General)

“Old Style Discontinued”			
REF	PART #	QTY	DESCRIPTION
			SEE SECTION
1	52510-LV	1	CASTING, MACHINED LOWER TURNTABLE
2	53104-LV	1	BOLT - 1.5-6NC" X 3"
3	19613-LV	1	WASHER, SAE FLAT - 1.5" (EXTRA THICK)
4	52559-LV	1	HUB, TAPER - 4.50"x 10 DEG
5	52562-LV	1	PIN - 4.5" X 19.38" DBL TAPERED TLVD.
6	53714-LV	2	SCREW, SET - 1" X 4.38" CHAMFERED END
7	15671-LV	2	NUT, JAM - 1"
8	19384-LV	1	WASHER, BURNED - 2.12" ID X 6" OD X .5"
9	10791-LV	2	NUT, JAM - 2"-12NF -
10	52589-LV	1	PLATE, SLACK ADJUSTMENT FRONT
11	15657-LV	2	ELBOW, 90 SWIVEL - 1501-2-2
12	52513-LV	1	<input type="checkbox"/> LEVELER, INTERMEDIATE SECTION
13	52522-LV	4	BUSHING - 3.75" X 3.25" X 3.0"
14	52523-LV	2	BUSHING - 5.0" X 4.5" X 4.25"

Kit or Assembly - includes all items indented underneath.

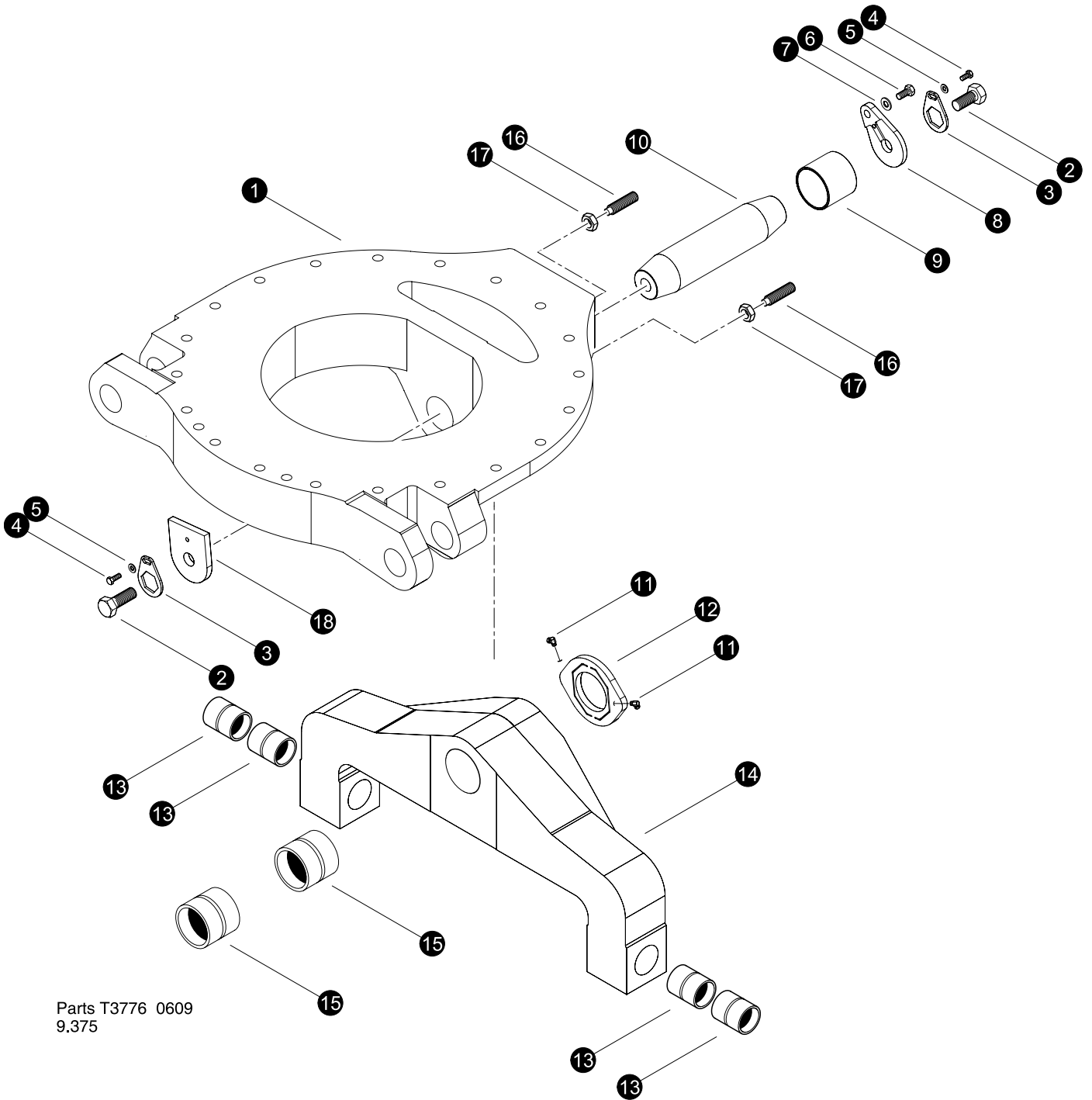

Leveling Components (General)

Machine 725B-0028-080709 and Before

REF	PART #	QTY	DESCRIPTION	SEE SECTION
1	52510-LV	1	CASTING, MACHINED LOWER TURNTABLE	
2	53104-LV	2	BOLT - 1.5-6NC" X 3"	
3	43740-LV	2	PIN LOCK, 2.25 HEX	
4	10783-LV	2	BOLT - .5" X 1"	
5	15534-LV	2	WASHER, SAE FLAT - .5"	
6	10839-LV	1	BOLT - .75" X 1.5"	
7	15550-LV	1	WASHER, SAE FLAT - .75"	
8	43742-LV	1	EAR, PIN LOCK BASE	
9	52559-LV	1	HUB, TAPER - 4.50"x 10 DEG	
10	53821-LV	1	PIN - 4.5" X 16.62" DBL TAPERED THD.VOID	
11	15657-LV	2	ELBOW, 90 SWIVEL - 1501-2-2	
12	52589-LV	1	PLATE, SLACK ADJUSTMENT FRONT	
13	52523-LV	4	BUSHING - 5.0" X 4.5" X 4.25"	
14	52513-LV	1	LEVELER, INTERMEDIATE SECTION	
15	52523-LV	2	BUSHING - 5.0" X 4.5" X 4.25"	
16	53714-LV	2	SCREW, SET - 1" X 4.38" CHAMFERED END	
17	15671-LV	2	NUT, JAM - 1"	
18	43741-LV	1	EAR, .75 THICK	

Kit or Assembly - includes all items indented underneath.

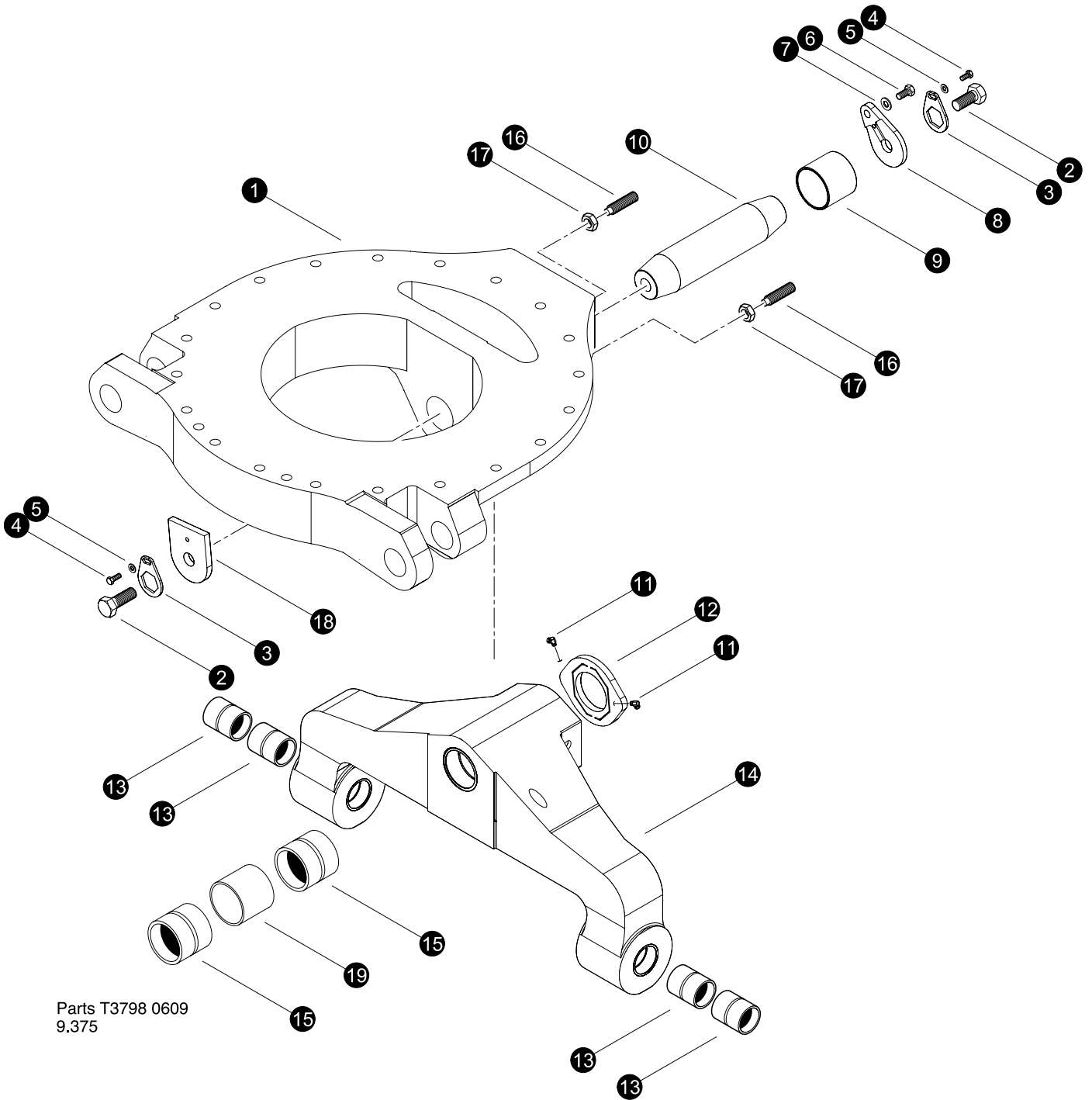

Leveling Components (General)

Machine 735B-0029 and After

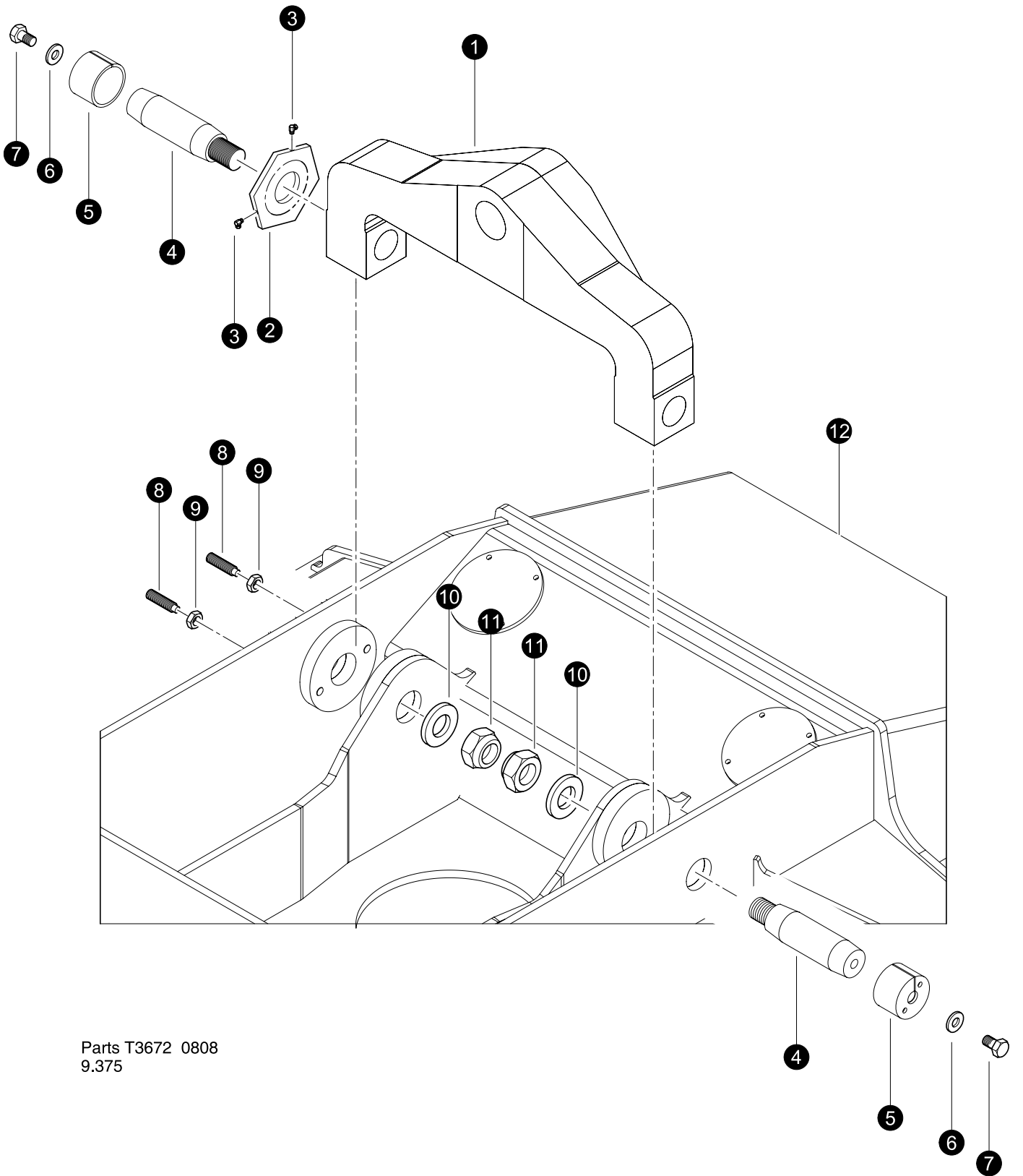

REF	PART #	QTY	DESCRIPTION	SEE SECTION
1	53861-LV	1	CASTING, MACHINED LOWER TURNTABLE +3	
2	53104-LV	2	BOLT - 1.5-6NC" X 3"	
3	43740-LV	2	PIN LOCK, 2.25 HEX	
4	10783-LV	2	BOLT - .5" X 1"	
5	15534-LV	2	WASHER, SAE FLAT - .5"	
6	10839-LV	1	BOLT - .75" X 1.5"	
7	15550-LV	1	WASHER, SAE FLAT - .75"	
8	43742-LV	1	EAR, PIN LOCK BASE	
9	52559-LV	1	HUB, TAPER - 4.50"x 10 DEG	
10	53853-LV	1	PIN - 4.5" X 19.62" DBL TAPERED THD. +3"	
11	15657-LV	2	ELBOW, 90 SWIVEL - 1501-2-2	
12	52589-LV	1	PLATE, SLACK ADJUSTMENT FRONT	
13	52522-LV	4	BUSHING - 3.75" X 3.25" X 3.0"	
14	53860-LV	1	LEVELER, INTERMEDIATE SECTION +3	
15	52523-LV	2	BUSHING - 5.0" X 4.5" X 4.25"	
16	53714-LV	2	SCREW, SET - 1" X 4.38" CHAMFERED END	
17	15671-LV	2	NUT, JAM - 1"	
18	43741-LV	1	EAR, .75 THICK	
19	54532-LV	1	SPACER,	

Kit or Assembly - includes all items indented underneath.



Parts T3672 0808
9.375

Leveling Yoke Installation

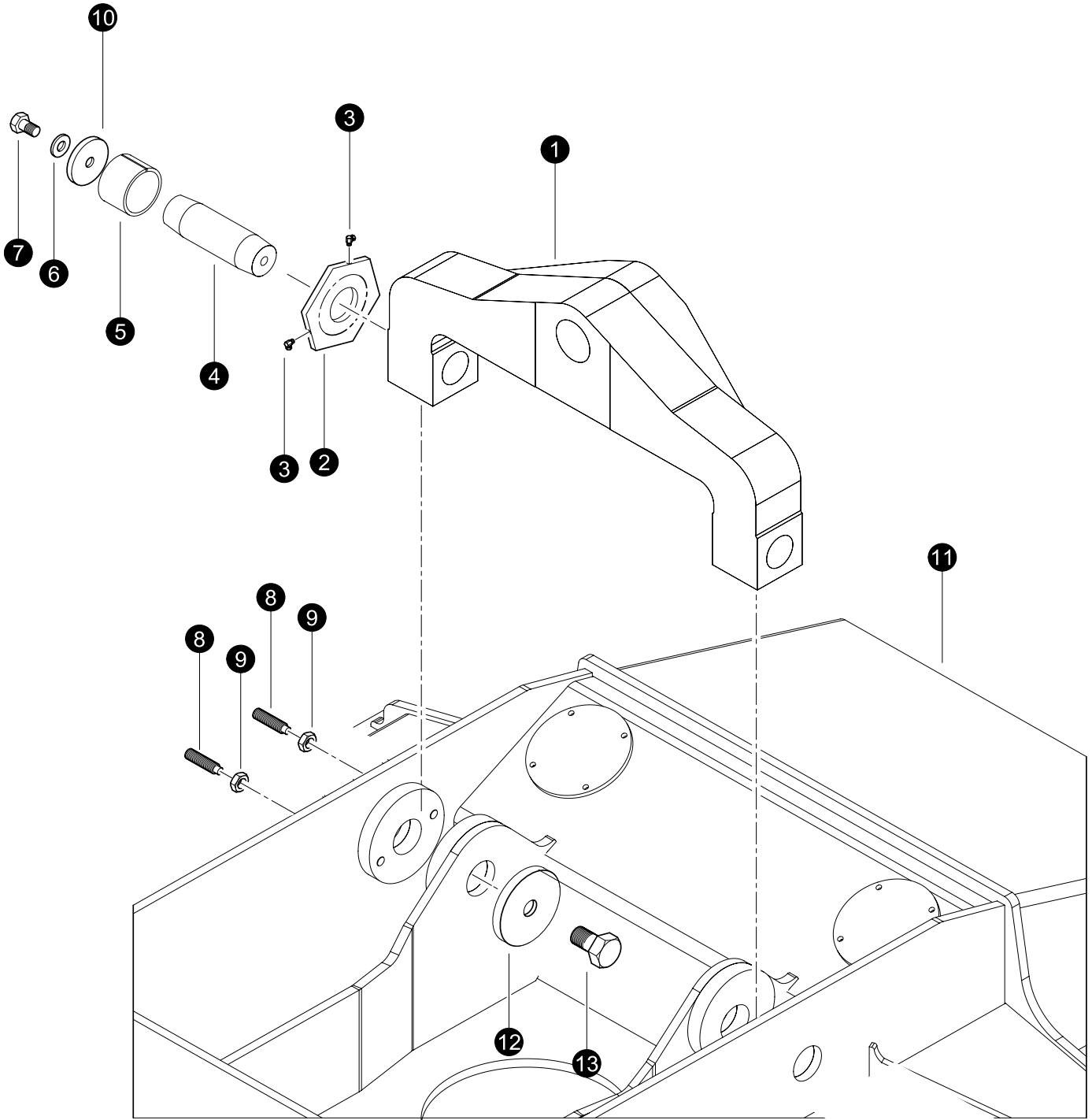

REF	PART #	QTY	DESCRIPTION	SEE SECTION
1	REF.	1	 LEVELING YOKE	LV-2
2	52588-LV	1	PLATE, SLACK ADJUSTMENT SIDE	
3	15657-LV	2	ELBOW, 90 SWIVEL - 1501-2-2	
4	52560-LV	2	PIN - 3.25" X 13.63" DBL TAPERED THD	
5	52558-LV	2	HUB, TAPER - 3.25"x 7 DEG	
6	15552-LV	2	BOLT - 1" X 2.5"	
7	52638-LV	2	WASHER, BURNED - 1 1/16" X 3" x 1/2"	
8	53714-LV	2	SCREW, SET - 1" X 4.38" CHAMFERED END	
9	15671-LV	2	NUT, JAM - 1"	
10	12021-LV	2	WASHER, BURNED	
11	10728-LV	1	NUT, NYLOCK - 2" (ZINC PLATED)	
12	REF.	1	 LEVELING TRACK CARBODY	LV-1

 See referenced page for component or assembly breakdown.



Parts T3896 0512
9.375

Leveling Cylinder Installation

REF	PART #	QTY	DESCRIPTION	SEE SECTION
1	REF.	1	 LEVELING YOKE	LV-2
2	52588-LV	1	PLATE, SLACK ADJUSTMENT SIDE	
3	15657-LV	2	ELBOW, 90 SWIVEL - 1501-2-2	
4	53820-LV	2	PIN - 3.25" X 11.12" DBL TAPERED THD CUR	
5	52558-LV	2	HUB, TAPER - 3.25"x 7 DEG	
6	-LV	2	WASHER, 1"	
7	15552-LV	2	BOLT - 1" X 2.5"	
8	53714-LV	2	SCREW, SET - 1" X 4.38" CHAMFERED END	
9	15671-LV	2	NUT, JAM - 1"	
10	52638-LV	2	WASHER, BURNED - 1 1/16" X 3" x 1/2"	
11	REF.	1	 LEVELING TRACK CARBODY	LV-1
12	53764-LV	1	WASHER, Burned	
13	-15552-LV	2	BOLT - 1" X 2.5"	



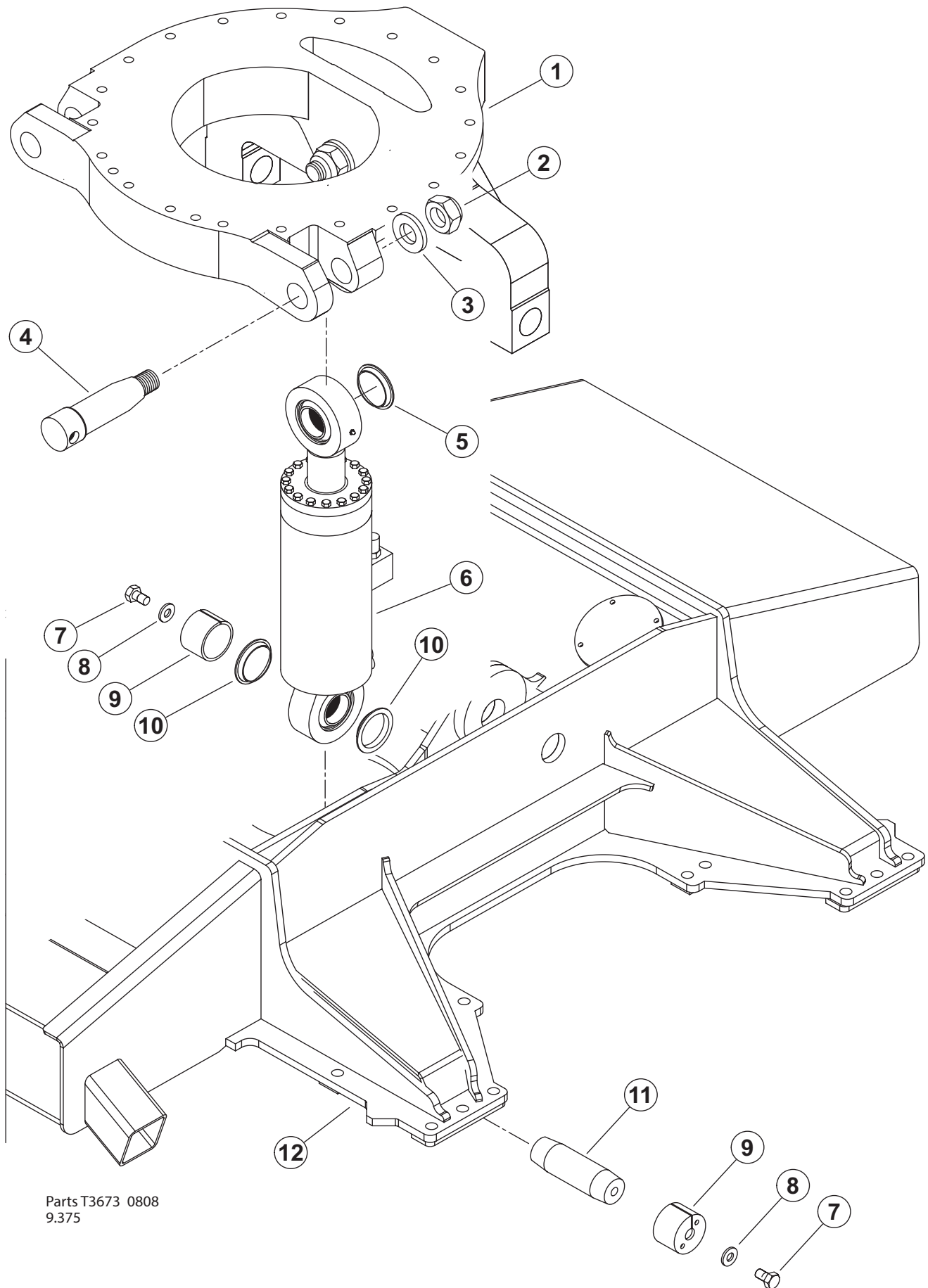

See referenced page for component or assembly breakdown.



Parts T3673 0808
9.375

Leveling Cylinder Installation

REF	PART #	QTY	DESCRIPTION	SEE SECTION
1	REF.	1	 LOWER TURNTABLE	LV-2
2	10728-LV	2	NUT, nylock - 2"	
3	12021-LV	2	WASHER, burned	
4	52520-LV	2	PIN, PIVOT LEVELING 3.25" X 15.5"	
5	52521-LV	2	SPACER - 3.25" x 1"	
6	REF.	2	 LEVEL CYLINDER	LV-3
7	15552-LV	4	BOLT - 1" X 2.5"	
8	52638-LV	4	WASHER, BURNED - 1 1/16" X 3" x 1/2"	
9	52558-LV	4	HUB, TAPER - 3.25"x 7 DEG	
10	52565-LV	4	SPACER - OD 4.50" x ID 3.25" X .700"	
11	52561-LV	2	PIN - 3.25" X 8.0" DBL TAPERED-CYL BASE	
12	REF.	1	 LEVELING TRACK CARBODY	LV-1



See referenced page for component or assembly breakdown.

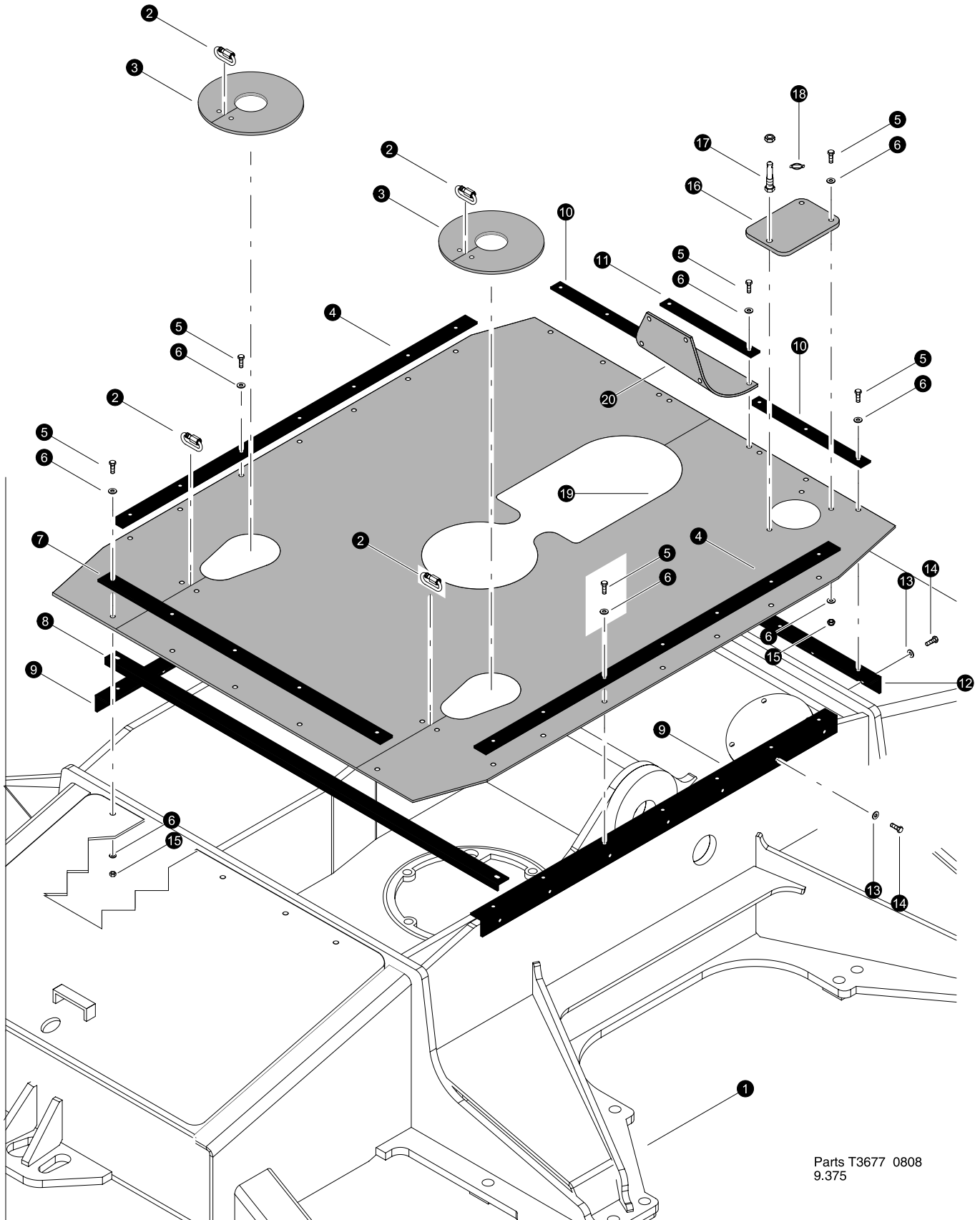

Parts T3677 0808
9.375

Debris Shield Installation

REF	PART #	QTY	DESCRIPTION	SEE SECTION
1	REF.	1	 FRONT FRAME WELDMNT	LV-1
2	18578-LV		LINK, QUICK - BEARING AREA DEFLECTOR	
3	53663-LV	2	SKIRTING, LEVELING CYLINDER	
4	53235-LV	2	BAR, RETAINER SKIRTING SIDE	
5	15604-LV	31	BOLT - .25" X .75"	
6	10757-LV	40	WASHER, SAE FLAT - .25"	
7	53236-LV	1	BAR, RETAINER SKIRTING REAR	
8	53647-LV	1	ATTACHMENT, SKIRTING TOP REAR	
9	53233-LV	2	ATTACHMENT, SKIRTING SIDE	
10	53234-LV	2	BAR, RETAINER SKIRTING FRONT ENDS	
11	53259-LV	1	BAR, RETAINER SKIRTING FRONT CENTER	
12	53232-LV	1	ATTACHMENT, SKIRTING FRONT	
13	10757-LV	21	WASHER, SAE FLAT - .25"	
14	15604-LV	21	BOLT - .25" X .75"	
15	10811-LV	7	NUT, LOCK - .25"	
16	53662-LV	1	SKIRTING, FUEL FLAP	
17	-LV	1	PIN, Hood Lock	
18	52464-LV	1	PIN, HITCH CLIP - .25	
19	53660-LV	1	SKIRTING, MAIN - FULL LENGTH	
20	53661-LV	1	SKIRTING, FRONT CASTING	

 See referenced page for component or assembly breakdown.

