

# TL755D - Feller Buncher

## West Coast Edition

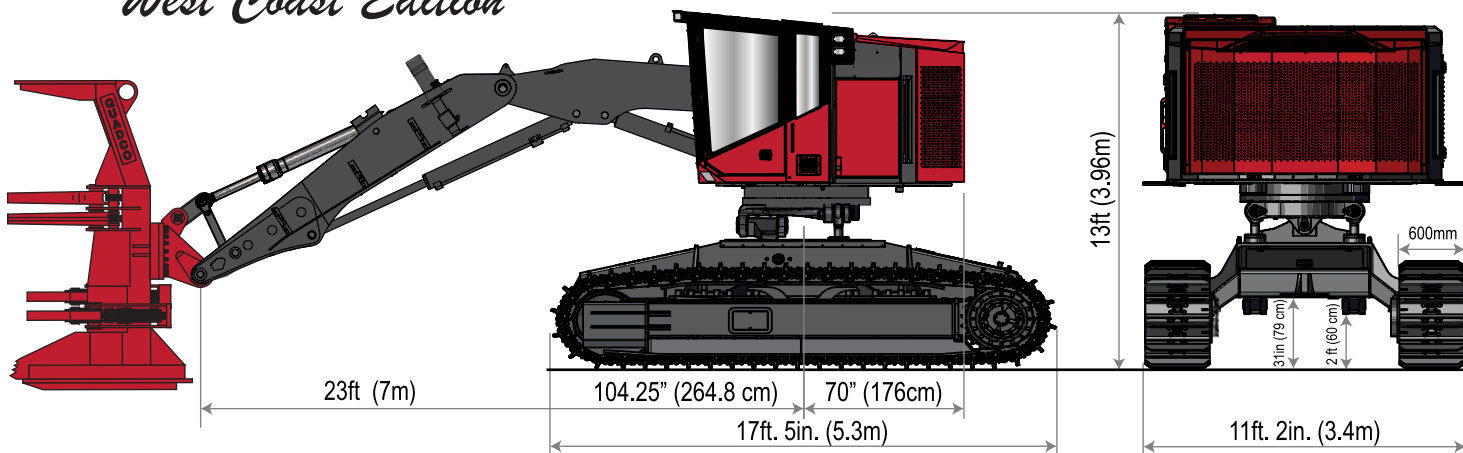

TimberPro Inc reserves the right to change specifications without notice or obligation. Product illustrations may be equipped with non-standard equipment.

### Engine:

Cummins L9 Series Engine  
Single Module DOC/DPF/SCR  
Max HP - 350 hp (261 kw)  
1151 lb-ft (1561 N-m) @ 1400 RPM  
Fuel Tank, Max - 251 gallons (950 Liters)

### Cooling:

Fan - 42" Hydraulic Driven, Variable Speed with  
Auto Reversing Feature  
Gear Box Cooler - Optional

### Control System:

IQAN MD4 HD control system

- 10" touch screen
- Engine Management
- Troubleshooting Diagnostics
- Over and Under Temperature Protection
- Auto-Accumulator Arm Feature
- Auto-Leveling Feature

### Electrical System:

Alternator - 100 amp 24 Volt  
Batteries - 2 /12 Volt @ 1000 CCA  
Work Lights - LED High Intensity Lighting

### Serviceability:

Rear Gull Wing Canopy Opens to Access to  
Engine and Hydraulic Components  
Side Access Service Doors  
Adjustable Side Service Platforms  
Retractable step for operators cabin  
Hydraulic Tank Vacuum System

### Hydraulic System:

Implement Pump - 175cc Variable Disp Piston  
Aux Saw Pump - Dedicated 60cc Piston  
Swing Pump - Dedicated 90cc Hydrostatic  
Drive Pumps - Dedicated 90cc Dual Hydrostatic  
Charge Pump - Gear Pump 50cc  
Valve - Parker L90LS / K220  
Electric hyd oil fill pump

### Filtration System:

Charge Filter Non By-Pass 6 micron  
Return Filters w/By-Pass 10 micron  
Case Drain Filter w/By-Pass 10 micron

### Upper Turntable Swing:

Gearbox - Rexroth GFB17 (32.5:1)  
Swing Motor - Rexroth Bent Axis - 56cc  
Hydrostatic energy recovery system  
Swing Torque: 64,608 ft-lbs (87,596 N-m)  
Continuous Rotation Swing

### Leveling System:

Front - 22 Degrees  
Rear - 8 Degrees  
Side - 20 Degrees  
(One Touch) Auto-Leveling

### Safety:

ANSUL LVS 15 Gallon Liquid Agent Fire  
Suppression System  
Removable Service Catwalks

### Machine Weight:

Base Machine: 78,000 lbs (35,380 kg)

*(approximate "woods ready" operating weight without attachment)*

### Boom Performance: (Buncher)

Maximum Reach (Pin Point) - 23ft (7m)  
Lift Capacity Max Reach: 13,800 lbs (6,260 kg)  
Lift Capacity 15' Reach: 24,700 lbs (11,204 kg)

### Undercarriage:

Caterpillar 330 Frame w/345 Recoil Spring  
Track Pitch - 8.5 Inch Pitch  
Track Pads - 51 - D7G HD (600, 700 or 800mm)  
Track Rollers - 10 (8 - Double and 2 - Single)  
Final Drive - Rexroth GFT 8190 - 121.1:1 Ratio  
Drive Motors - 170cc Auto Shift Rexroth  
Tractive Effort - 108,745 lbs (484 kN)  
Tractive Effort to Weight ratio - 1.2:1  
Travel Speed - 0 to 3.5 mph  
Winch Assist / Tethering Hitch (Standard)

### Operators Cabin:

ROPS/FOPS/OPS Certified cabin  
Digital Climate Control System  
Three Emergency Escape routes  
Fresh air filtered & Pressurized cabin  
AM/FM/WB - Bluetooth/Handsfree - USB  
Deluxe Seat - Air ride, Heat & Lumbar  
Rear View Camera System  
5 Point Harness Option

**TIMBERPRO**  
[www.timberpro.com](http://www.timberpro.com)