

# TIMBERPRO TL775D Leveling



## L9 Engine Provides:

- 365 Hp (272 kW)
- 1151 lb-ft Torque
- Increased fuel economy and longer maintenance intervals
- Single-Module™ aftertreatment system Certified to Stage V

- ❑ Cummins L9 Engine
- ❑ Dual Hydrostatic Drive System
- ❑ Dual Motor Hydrostatic Slewing System
- ❑ IQAN 10" Touch Screen Control System
- ❑ Digital Climate Control System
- ❑ Larger Windows for Increased Visibility
- ❑ High Output LED Lighting
- ❑ Handsfree Stereo System
- ❑ Best in Class Serviceability



The TimberPro TL775D is the largest of the D-Series purpose built track machines. Designed exclusively for the forest industry the TL775D was built to handle extreme terrain and severe climates.

The leveling undercarriage of the TL775D has long heavy duty track frames and a wide stance making it extremely robust and very stable.

Equipped with a powerful Cummins L9 engine, a technologically advanced IQAN MD4 touch screen control system, dual motor hydrostatic slewing system and a dedicated dual hydrostatic track drive system the TL775D is the perfect balance of power, performance and productivity.

# TL775D - Harvester

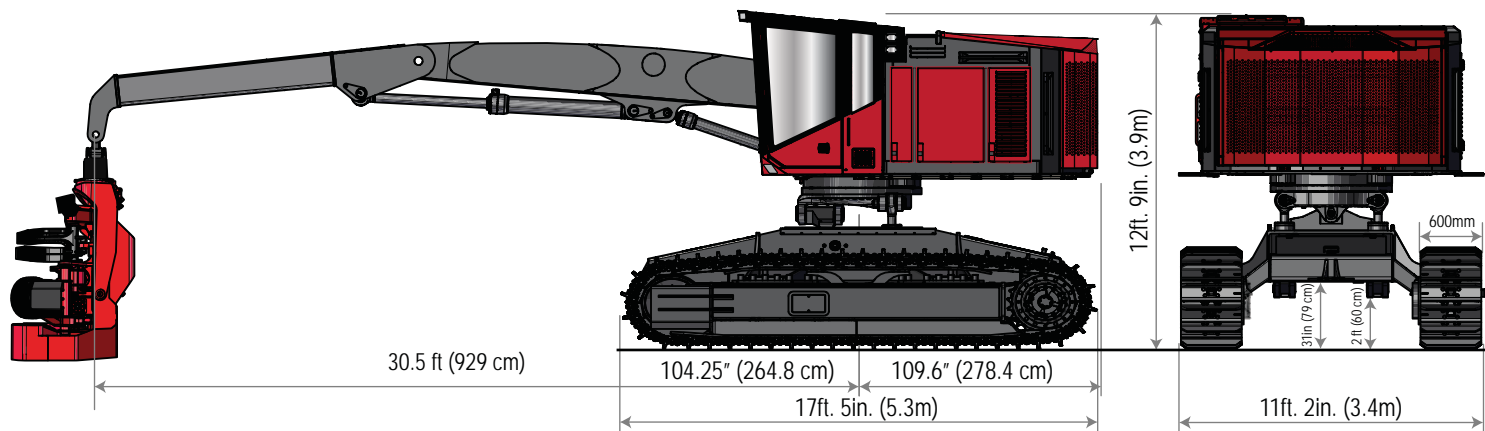

TimberPro Inc reserves the right to change specifications without notice or obligation. Product illustrations may be equipped with non-standard equipment.

## Engine:

Cummins L9 Series Engine - 365HP  
 Single Module DOC/DPF/SCR  
 Max HP - 365 hp (272 kw)  
 Peak Torque - 1151 lb.ft. (1561 nm) @ 1400  
 Fuel Tank - 250 gallons (946 Liters)

## Cooling:

Fan - 42" Hydraulic Driven, Variable Speed with  
 Auto Reversing Feature  
 Gear Box Cooler - Optional

## Control System:

IOAN MD4 HD control system

- 10" touch screen
- Engine Management
- Troubleshooting Diagnostics
- Over and Under Temperature Protection
- Auto-Accumulator Arm Feature
- Auto-Leveling Feature

## Electrical System:

Alternator - 100 amp 24 Volt  
 Batteries - 2 /12 Volt @ 1000 CCA  
 Work Lights - LED High Intensity Lighting

## Serviceability:

Rear Gull Wing Canopy Opens to Access to  
 Engine and Hydraulic Components  
 Side Access Service Doors  
 Adjustable Side Service Platforms  
 Retractable step for operators cabin  
 Hydraulic Tank Vacuum System

## Hydraulic System:

Implement Pump - 175cc Variable Disp Piston  
 Swing Pump - Dedicated 90cc Hydrostatic  
 Track Drive - Dedicated 90cc Dual Hydrostatic  
 Aux Saw Pump - Dedicated 60cc Piston  
 Charge Pump - Gear Pump 50cc  
 Valve - Rexroth M7 / M4  
 Electric hyd oil fill pump

## Filtration System:

Charge Filter Non By-Pass 6 micron  
 Return Filters w/By-Pass 10 micron  
 Case Drain Filter w/By-Pass 10 micron

## Upper Turntable Swing:

Gearboxes - Dual Rexroth GFB17 (32.47:1)  
 Bearing - Dual Ball / External Tooth  
 Swing Motors - Dual Rexroth Bent Axis - 56cc  
 Hydrostatic energy recovery system  
 Swing Speed - 5.6 RPM  
 Swing Torque - 113,811 Ft/LBS (154,307 Nm)  
 Swing Brake - Wet Multi-Disc (95,000 ft-lbs)  
 Continuous Rotation Swing

## Leveling System:

Front - 22 Degrees  
 Rear - 8 Degrees  
 Side - 20 Degrees  
 (One Touch) Auto-Leveling

## Safety:

ANSUL LVS 15 Gallon Liquid Agent Fire  
 Suppression System

## Machine Weight:

Base Machine: 96,200 lbs (43,636 kg)  
 Ground Pressure: 600mm - 10.7 psi (standard)  
 700mm - 9.2 psi (optional)  
 800mm - 8.5 psi (optional)

*(approximate "woods ready" operating weight without attachment)*

## Boom Performance:

Maximum Reach (Pin Point) - 30.5 ft (9.3 m)  
 Lift Capacity @ Max Reach - 10,500 lbs (4,763 kg)

## Undercarriage:

Caterpillar 330 Frame w/345 Recoil Spring  
 Track Pitch - 8.5 Inch Pitch  
 Track Pads - 51 - D7G HD (600, 700 or 800mm)  
 Track Rollers - 10 (8 - Double and 2 - Single)  
 Final Drive - Rexroth GFT 8190 - 121.1:1 Ratio  
 Drive Motors - 170cc Auto Shift Rexroth  
 Tractive Effort - 108,745 lbs (484 kN)  
 Tractive Effort to Weight ratio - 1.2:1  
 Travel Speed - 0 to 3.5 mph  
 Winch Assist / Tethering Hitch (Standard)

## Operators Cabin:

ROPS/FOPS/OPS Certified cabin  
 Digital Climate Control System  
 Three Emergency Escape routes  
 Fresh air filtered & Pressurized cabin  
 AM/FM/WB - Bluetooth/Handsfree - USB  
 Deluxe Seat - Air ride, Heat & Lumbar  
 Rear View Camera System

[www.timberpro.com](http://www.timberpro.com)